



The New York City Bus Depot

New York, NY

Table of Contents:

Executive Summary:	2
Building Introduction (Existing Conditions):	3
Structural Overview	5
Foundations:	5
Floor Systems:	5
Framing System	6
Lateral System	6
Roof Systems	8
Design Codes	8
Materials Used	8
Gravity Loads:	
Dead and Live Loads	9
Snow Loads	11
Column Gravity Check	12
Slab/Decking Gravity Check	12
Beam Check	13
Girder Check	13
Lateral Loads:	
Wind Loads:	14
Seismic Loads:	16
Conclusion:	17
Appendices:	
Appendix A: Gravity Load Calculations	18
Appendix B: Wind Load Calculations	22
Appendix C: Seismic Load Calculations	24
Appendix D: Framing Plans	25
Appendix E: Distributed Loads	31

Executive Summary:

The following technical report gives a summary of the existing structural conditions of the New York City Bus Depot using the 2010 New York State Building Code for analysis. The plans and images for this building are provided by STV Incorporated. Permissions for use are provided by the New York City Transit Authority. Analyses of the features of this building, which utilize the 2010 New York State Building Code, follow the guidelines and standards outlined by the 2006 International Building Code and ASCE7-05 when applicable.

Loads on the building are provided and shown in Appendix F. All calculations performed using these loads employ Allowable Stress Design as dictated in the structural drawing general notes. Gravity checks are accomplished with these load combinations which yield results showing that many member sizes are near failure. Analysis for the beam shows that the W24x84 is acceptable in its location. Analysis of the W33x130 girder shows that the next size up, W33x130, is necessary for adequate design. The slab shown, if treated as a composite decking system, is more than adequate for the loads utilized for the design. According to the structural engineer, however, the slab is not to be treated as such, but instead as a 6" reinforced concrete slab, making the 2" 18 gage decking sacrificial. The column analyzed here also shows that a larger member size is necessary for adequate design. The flaws in the analysis are likely due to discrepancies in the weight of the building, as was discovered just prior to report's deadline. A late piece of information from the structural engineer at STV shows that the overall building weight used in the following analyses is 30,000k above the actually weight.

Examinations of the lateral system show that seismic loads are the prevailing lateral forces on the structure. Wind analysis yields an overturning moment of 133,670k.ft in the north-south direction with a base shear of 1438kips. In the east-west direction it yields an overturning moment of 40,587k.ft with a base shear of 436.4kip. The net wind pressures calculated prior to the overturning moments and the base shears indicate an error of 20% below the expected value. This error, again, is likely due to inaccurate assumptions.

The seismic results are compared to the base shears provided in the first pages of the structural drawing set. The base shear in the north south direction yields a result of 3848k. This is an error of only 3.5% from the base shear presented in the drawings. The base shear in the east-west direction is 4079k which is 7.4% greater than then base shear presented in the drawings. These values result with minimal error despite the issues with weight calculation.

Due to accuracy of the results and new information gained from the project's structural engineer at STV Incorporated, it can be determined that more information is necessary. Further analysis of this structure beyond the 65% submittal drawings is required in order to gain a better perspective on the adequacy of members.

Building Introduction (Existing Conditions):

The New York City Bus Depot is a new design-build project that broke ground in June of 2011. This \$150 million project is slated for completion in January of 2012. The building site can be seen below in Figure 1 highlighted in red. It is in an area that is currently zoned to be commercial specifically for heavy automotive repair shops that are used for community purposes. The region where this building is to be located was once the place of a river that ran through this part of the city. For this reason, the water table on the site is high and the soil is liquefiable. There is also a portion of the site where there is no solid rock creating a need for piles to be driven down as deep as 150 feet.

The New York City Bus Depot is on a plot of land that is being reused. It was once a former trolley barn in the 1800s and, prior to the most recent demolition, an out-of-date, undersized bus depot that needed expansion for use by the New York City Transit Authority. This new and more environmentally friendly 390,000 square foot bus station will contain facilities for a fleet of 150 busses. The depot will be three stories tall, with each story at an approximate height of 25 feet. On the first floor, facilities will be available for bus refueling, servicing, fare collection, bus washing, and maintenance. The second and third floors will house parking for each of the 150 busses stationed out of the depot. Included in the space will also be offices for employees stationed at the bus depot.

Externally, this new facility has a modern appearance with a corrugated metal and brick veneer anchored onto CMU walls as seen in Figure 2. Large, rectangular expanses of windows with aluminum frames help to provide well lit spaces while using minimal electric lighting. The brise soleil that line the tops of the windows on the East façade to control the sunlight entering the building, helping to achieve the most energy efficient performance possible. To pay homage to the vibrant culture of the neighborhood in which the depot is located, artwork will be placed at street level for any passer-by to see. All of these features will help give life to an area of the borough looking to be renewed and revitalized.

In order to be an environmentally friendly facility, the New York City Bus Depot plans to employ green technologies. Two major highlights for this are located on top of the building: a green roof and a white roof. This green roof will help to minimize carbon dioxide emissions (particularly important for such a



Figure 1: Aerial view of the building site highlighted in red. (Image courtesy of Google Maps).



Figure 2: Rendering of the New York City Bus Depot showing its south face and both the corrugated metal and brick veneer facades. (Image courtesy of STV Inc.)

crowded borough of the city), and the white roof will help to regulate heat gain for the building. Other technologies to be included in the building are a rain water collection system, low emission boilers, heat recovery units, water efficient fixtures, recycled materials, and day-light centered lighting design. In addition to a rain water collection system, a water reclamation system is planned to recycle the water used in bus washing facility. All of these features aim to lead the New York City Bus Depot to a LEED certification upon completion of construction.

Structurally, this building is one which is steel framed. It has unique floor framing due to the multitudes of point loads applied from busses and their towing counterparts. Floors on levels two and three are also ramped like an over-sized parking garage for this bus fleet. Unique loading patterns are also created due to the busses as well as the mixed use occupancy of the building. At the present time, the building is at a 65% submittal stage with its contract documents and more information will be provided as updates are received.

Structural Overview

The New York City Bus Depot is a three story, 80' tall building that rests on piles grouped together with caps scattered throughout the site. The piles are deep due to the site class E classification that indicates the chance for liquefaction of the soil. The building itself can be treated as three separate buildings due to the large expansion gaps that separate the framing systems of the building. The first floor consists of a heavily reinforced slab that is 14" to 18" thick for travel by heavy busses and towing vehicles. The framing system consists of heavy steel beams that are designed to resist the loads caused by the traveling busses. On top of each level of this steel framing sits a 6" reinforced concrete slab. This slab is supported by 2" 18 gage metal deck, however this deck is considered as sacrificial and all designs are calculated as though there is simply a concrete deck sitting upon the steel beams.

Foundations:

The New York City bus depot requires the use of deep pile foundations due to the site's soil conditions. The site contains layers of organic material that compress under long-term loading, making the site unsuitable to maintain a shallow foundation. Another reason for the pile foundation lies in the liquefaction potential of the soils. Those below the water table, which is about 8' below the site surface, consist of a stratum of sand and a stratum of silt and clay all over weathered rock and bedrock. When tested, it was deemed that these would likely not liquefy during a strong earthquake, but there were some local areas that showed liquefaction potential if the 2500-year event were to occur in the city.

The piles recommended for the site are steel HP12x102 piles that possess the ability to maintain 220 tons (or a service load of 200tons after subtracting 20 tons of downdrag). These piles are used to support the ground floor structural slabs, columns, and heavy equipment requiring extra reinforcing. They terminate at an elevation 107'-6" above sea level. These piles are required to be driven down to bedrock, which is between 35' and 100' below grade depending on the area of the site. The piles must be hammered into the ground and have a final driving resistance no less than 5 blows per quarter inch of penetration. Also, because of the low pH of the ground water, corrosion effects must be taken into consideration. Due to the effects of this, the piles are to be analyzed for strength at a size 1/8" thinner in the webs and flanges than prescribed. In addition to being able to maintain 200 lbs of compression, the piles are to withstand a lateral load of 5.5kips for a single pile and 3.8kips for each pile when analyzed in groups in the pile caps.

Floor Systems:

Two flooring systems are considered in the New York City Bus Depot. On the first floor, there is a slab on grade with a thickness still to be determined. This thickness is to be between 14" and 18" due to the heavy, concentrated loads imposed by the various busses and maintenance vehicles utilizing the facility.

The typical flooring system on the second floor, third floor, and third floor mezzanine consists of steel beams and girders supporting 6" of concrete on a 2" gage composite form deck. This slab on deck is to be reinforced with a yet to be determined rebar layout. What controls the design of the reinforcement in the slab is not the distributed load, but instead the point loads induced by the buses. The span of this deck is also yet to be determined since the reinforcement has also yet to be determined.

Various beam sizes are used in construction of this structure because of the varying spans, many of which are much longer than the conventional 30 feet. Smaller spans under 30'-0" are generally made up of inlay beams of W14s, W16s, and W18s. Larger spans are made of W 24s, W27s, and W30s. Examples of these spans include W27x84s that span 49'-10" and W30x99s that span 55'-6". Girders utilized on these floors include W30s, W33s, W40s, and W44s.

On the west end of the building, ramps are utilized to lead busses to the parking areas on the second and third floors. These are also steel framed with same metal decking described as typical on other areas of the floor. They utilize W24x76s that span the following: 45'-0" on the North and South ends of the ramp and 44'-2" on the West end.

Framing System

The rest of the framing system of the New York City Bus Depot consists of steel columns. There are all W14s with the exception of one W15x655 in a moment frame that supports 1001kips of service dead load and 573kips of service live load. The columns can be expected to support rather large unbalanced moments as can be seen in the column gravity check later in this report (see appendix A for calculation details).

Lateral System

The lateral system for this building consists of two types of frames: braced and moment. Braced frames flank the interior runs of the ramps on the west side of the building and also run east to west on the exterior lines between column lines O and P. The moment frames are those which run north and south. They are located at column lines F, H.1, J.1, L, M, P.1, Q.1, S, T, U, and V.

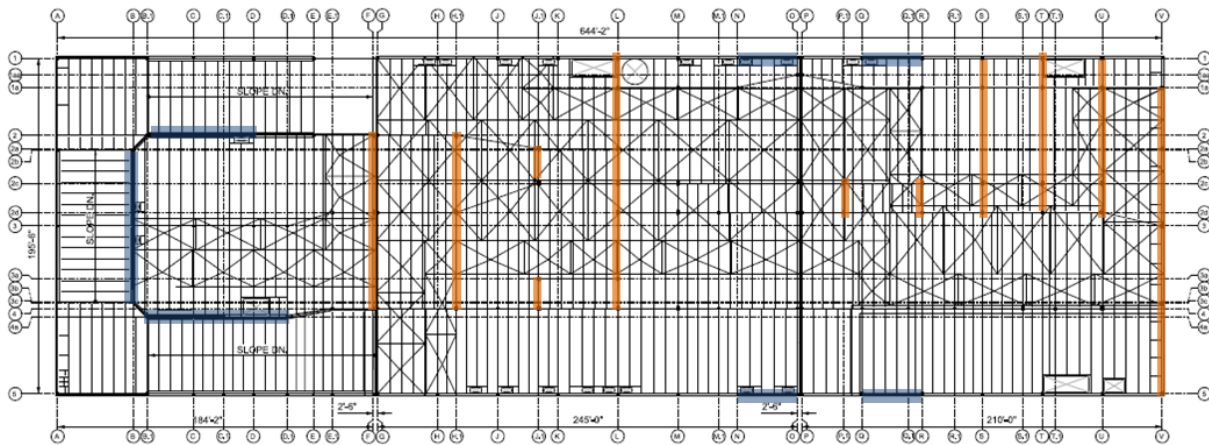

Typical Lateral Framing Plan

- = Braced Frame
- = Moment Frame

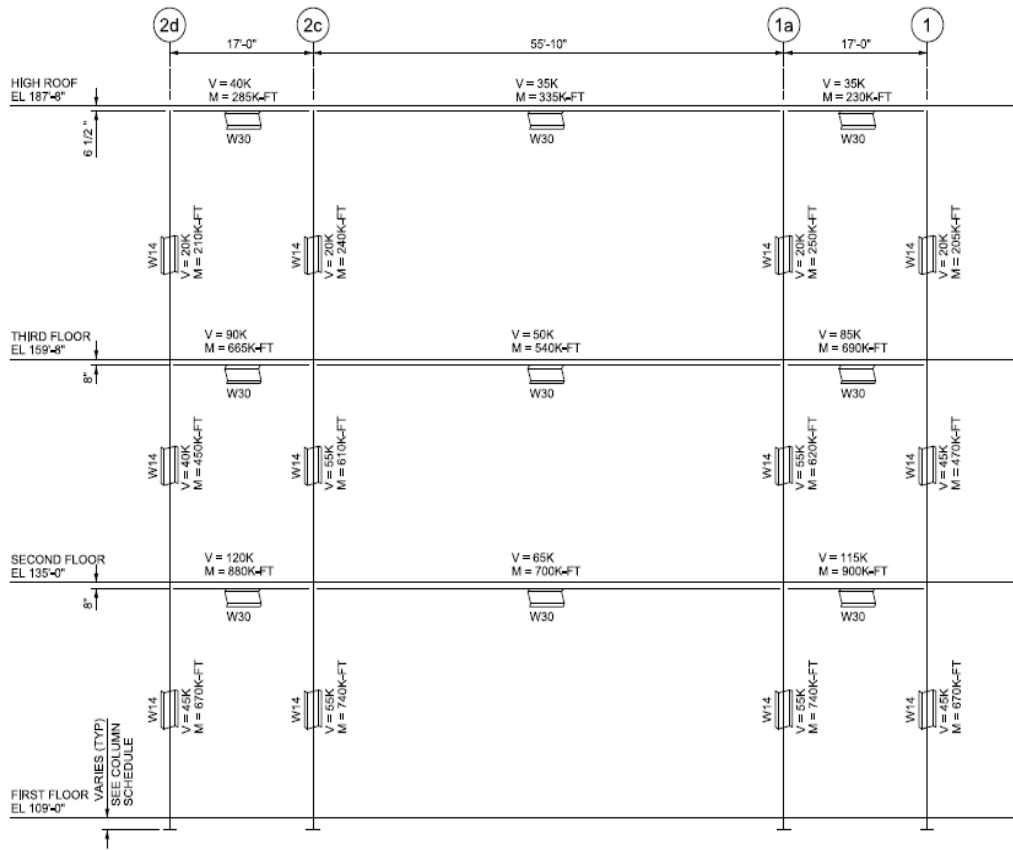

Typical moment frame construction

The moment frames are constructed of W14 columns and W30 beams assembled such that the controlling seismic loads may be supported. The moment frames are required to resist service loads ranging from shears of 5kips along the first floor columns of the frame running along F, to 455kips on the second floor beam along column line V between columns 5 and 3c. These must also resist moments from 1895kip-ft along column line V to 65kip-ft in first-floor column 2F. A typical construction of a moment frame is shown on the right.

The braced frames are constructed of W14 columns of significant weight with W12 members that act as bracing. The diagonal lines that can be seen to the right show the ramp in the garage. This location, on the west end of the bus depot, is most heavily reinforced with these braced frames due to the vibrations that the walls will have to handle from the traveling busses.

With the exception of one frame, all of the braced frames run from east to west. It is easy to use the braced frames on the west end of the building because there will be no interference with architectural features on the façade there. Windows are in place in the bus parking and office areas to the east, but not in the location of the ramp. Also, on the interior, where these are located will not interfere with bus travel lanes: a key component to the functionality of the bus depot.

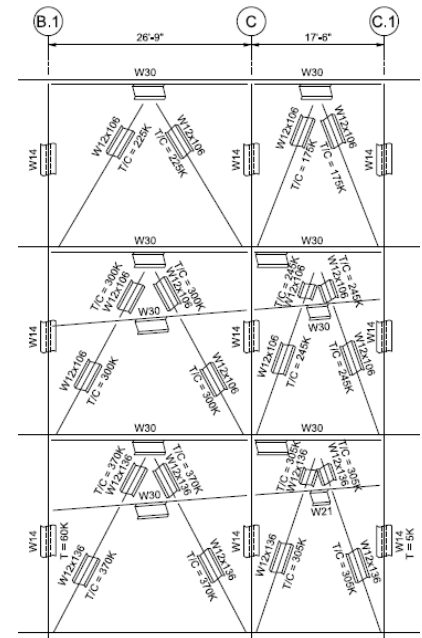

Typical braced frame construction.

Roof Systems

The roof of the building is framed similarly to the floors below in with respect to size and bay spacing. Certain bays, particularly those above the ramp, utilize smaller W21s because they do not need to be concerned with carrying the weight of the busses. Overall, the roof maintains a similar beam sizing because significant weight is still expected to be carried by the system. The roof will be supporting a green roof as well as a series of air handlers stationed along the north and south edges of the roof.

The decking on the roof shall consist of a 4 ½” concrete covering on a 2” 18 gage cold form metal deck. Reinforcement and span for the roof deck/slab system is yet to be determined at this stage of the project.

It should also be noted that the roof has two levels to it. The main roof consists of a diaphragm at 72’ and a parapet extending up to 80”. The 69’ swath of the roof furthest east is actually a bulkhead above the 3rd floor mezzanine where the office space is located. This tops off at a level of 93.’ This high level is used in computing wind loads so that the highest factor of safety is considered. See the Wind Load section for more details and Appendix B for calculations.

Design Codes

- 2010 Building code of New York State
 - Adopts 2006 Family of Codes (IBC, IRC, IFC, IMC, IPC, IFGC, IPMC, IEBC) and 2009 IECC
- North American Specifications for the Design of Cold Formed Structural Steel Members “AISI-NASPEC” (Metal Decking)
- 2008 New York City Building Code (Foundations)
- AISC Manual of Steel Construction – Allowable Stress Design, Thirteenth Edition
- Structural Welding Code – Steel (AWS D.1 - Modified by AISC Section J2)
- Details and Detailing of Concrete Reinforcement ACI 315
- Building Code Requirements for Structural Concrete ACI 318-08
- 2008 Building Code Requirements for Masonry Structures (ACI 530-08/ASCE 5-08/ TMS 402-08)
- Specifications for Masonry Structures (ACI 530.1-08/ASCE 6-08/TMS 602-08)

Materials Used (continued on next page)

Material Properties		
Material		Strength
Steel	Grade	fy = ksi
Wide Flange Shapes	A992	50
Hollow Structural Shapes	A500, GR. B	46
Plates	A572	50
Pipe Shapes	A53, GR. B	46
Anchor Rods	F1554	36
Sag Rods	A36	36
Welding Electrodes	E70XX	70

Welding Electrodes (Gr. 65)	E80XX	80
Steel Reinforcement	A615	60
Bolts (3/4"-1" dia.)	A325	N/A
Bolts (1-1/8" dia)	A490	N/A
Deck	Gage	
2" Form Galvanized Metal	18	
Concrete	Weight (pcf)	f'c = psi
Formed Slabs	150	5,000
Structural SOG	150	5,000
Slabs on Metal Deck	150	5,000
Foundations	150	5,000
Masonry	Grade	fy = ksi
Concrete Masonry Units	C90	1.9
Mortar	C270, Type M	N/A

Gravity Loads:

Dead and Live Loads:

The dead and live load distributions on the floors and roof can be seen in the plans in Appendix F. The following charts compare the dead and live loads utilized in the design with those outlined in the New York State Building Code:

Dead Loads:

Floor	Distributed Floor Dead Load (psf)	Area (ft ²)	Col. Wt (lb)	Exterior Façade (lb)	Weight per floor (k):
Floor 1	200	125902	502.5	1047696	25682.9
Floor 2	100	125902	922.3	1934208	13512.5
Floor 3	100	125902	622.2	1450656	13212.4
Floor 3 (Mezz)	100	13489.5	30	1128288	1378.95
Roof	100	112412.5	189.9	1128288	11431.15
High Roof	100	13489.5	18.4	564144	1367.35

In the New York State Building Code, dead loads are dictated to be the actual weight of construction materials. No superimposed loads are suggested, but in this project, they are included. The distributed floor dead load in the chart above does not include these values. This includes the slab weight and a 15psf beam allowance. Added to this, for total construction weight per floor, is the weight of the columns per floor, and the weight of the exterior façade, which is assumed to be 48psf. The additional superimposed dead loads are 10psf for the first floor; 35psf for the second floor, third floor, and third floor mezzanine; and 95psf for the roves.

Live Loads:

Floor	Function	Assigned Live Load (psf)	NYS Code 2010 Prescribed LL (psf)	Notes
Floor 1	Maintenance	250	50	See Chart: Concentrated Loads
	Storage	300	250	
Floor 2	Bus Parking	175	50	See Chart: Concentrated Loads
	Future Shop	250	250	
	Office	150	50	Compact, Versatile
	Vault	600	250	Undisclosed Use
Floor 3	Bus Parking	100	50	See Chart: Concentrated Loads
	Office	150	50	Compact, Versatile
Floor 3 (Mezz)	Office	150	50	Compact, Versatile
Roof	Roof	30	100	Green Roof

The live loads prescribed for the New York City Bus Depot are generally close to those dictated in the 2010 New York State Building Code. The reason for some of the larger discrepancies is due to the unique occupancy of the structure. Live loads for bus and truck parking garages are generally defined in linearly distributed loads along lanes and concentrated loads. Below are the New York State Building Code’s minimums for bus and truck parking facilities as well as the concentrated loads expected for the facility by the design engineers.

2010 New York State Building Code:

TABLE 1607.6 UNIFORM AND CONCENTRATED LOADS

LOADING CLASS ^a	UNIFORM LOAD (pounds/linear foot of lane)	CONCENTRATED LOAD (pounds) ^b	
		For moment design	For shear design
H20-44 and HS20-44	640	18,000	26,000
H15-44 and HS15-44	480	13,500	19,500

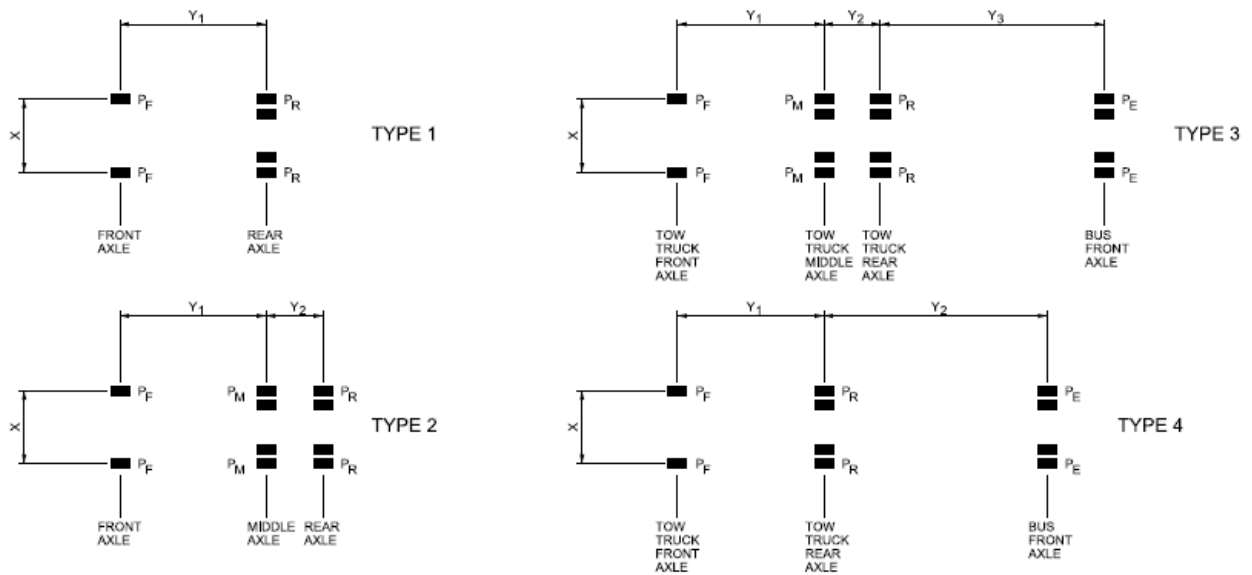

CONCENTRATED WHEEL LOAD DIAGRAMS

NOTE: THERE ARE SLIGHT VARIATIONS IN LOAD FOR P_F, P_M, P_R AND P_E. HOWEVER DESIGN IS BASED ON THE HIGHEST VALUE.

CONCENTRATED WHEEL LOAD TABLE											
VEHICLE	TYPE	LOCATION	X	Y ₁	Y ₂	Y ₃	P _F	P _M	P _R	P _E	
			(DIMENSIONS IN FEET)				(LOADS IN KIPS)				
STANDARD HS20 TRUCK	2	1st, 2nd, 3rd	6.0	14.0	14.0	-	4.0	16.0	16.0	-	
MCI 2915 BUS	2	1st, 2nd, 3rd	6.67	26.5	4.0	-	5.7	8.9	4.8	-	
ORION HYBRID "NEW GEN" 3877 BUS	1	1st, 2nd, 3rd	6.17	23.83	-	-	6.0	-	11.35	-	
VAN HOOL DOUBLE DECKER BUS TD 925	2	1st, 2nd, 3rd	7.17	16.58	4.25	-	5.72	8.91	5.72	-	
TOW TRUCK E050-08	2	1st, 2nd, 3rd	7.0	21.67	4.0	-	9.75	8.5	6.6	-	
TOW TRUCK E052-03	1	1st	7.0	23.0	-	-	9.9	-	9.1	-	
TOW TRUCK E050-08 LIFTING MCI 2915 BUS	3	1st, 2nd, 3rd	7.0	21.67	4.0	45.33	5.57	15.44	15.07	10.08	
TOW TRUCK E052-03 LIFTING MCI 2915 BUS	4	1st	7.0	23.0	45.33	-	5.88	-	23.94	10.08	
TOW TRUCK E050-08 LIFTING ORION 3877 BUS	3	1st, 2nd, 3rd	7.0	21.67	4.0	39.67	4.31	15.59	15.65	7.77	
TOW TRUCK E052-03 LIFTING ORION 3877 BUS	4	1st	7.0	23.0	39.67	-	4.73	-	26.57	7.77	
TOW TRUCK E050-08 LIFTING DOUBLE DECKER BUS TD 925	3	1st, 2nd, 3rd	7.0	21.67	4.0	35.67	5.57	15.87	15.45	10.08	
TOW TRUCK E052-03 LIFTING DOUBLE DECKER BUS TD 925	4	1st	7.0	23.0	35.67	-	5.88	-	24.69	10.08	
OPEN TOP CONTAINER TRUCK	2	1st, 2nd	7.0	9.0	4.5	-	13.0	13.5	13.5	-	

NOTE: WHEN TOWED BUS LOADS ARE APPLIED SIMULTANEOUSLY WITH OTHER WHEEL LOADS ON A COMMON MEMBER, TOWED BUS WHEEL LOADS ARE REDUCED BY 25%. SIMULTANEOUS VEHICLE LOADS HAVE BEEN ANALYZED PER THE STALL LAYOUT SHOWN ON THE ARCHITECTURAL DRAWINGS, COMBINATIONS OF VEHICLE TYPES WERE PLACED IN EACH STALL GROUP IN SUCH A WAY TO PRODUCE THE WORST CASE LOADING FOR THE MEMBER BEING STUDIED.

Snow Loads

Snow Loads for the New York City Bus Depot are minimal. They were included in the distributed loads where applicable so no additional calculations were necessary for them. The chart on the right is a display of the design criteria for the snow loading.

SNOW DESIGN CRITERIA	
SNOW IMPORTANCE FACTOR, I _s : 1.0	
OCCUPANCY CATEGORY: I	
GROUND SNOW LOAD, p _g : 25 PSF	
EXPOSURE FACTOR, C _e : 0.80	
THERMAL FACTOR, C _t : 1.00	
FLAT ROOF SNOW LOAD, p _f : 15.75 PSF	
SNOW DRIFT LOAD: INCLUDED WHERE APPLICABLE	

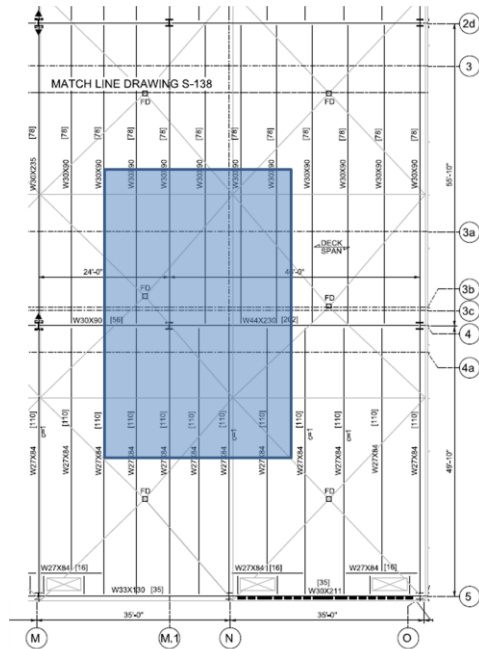

Column Gravity Check:

The column checked in this analysis is M.1-4. There are three stacked in this series. The column supporting the roof passes the equivalent axial force, however the lower two columns do not. Had they been sized-up by one more size each, then they would pass. This result is likely due to a miscalculation of loads on the building. The weight that was calculated and shown earlier in the report proved to be approximately 30,000k heavier than the one presented by the structural engineer just before the due date of this report.

Shown to the left is the column and its tributary area highlighted in blue. Further detail on the calculation is available in Appendix A.

Slab/Decking Gravity Check:

The slab for this analysis passes with ease. In the 65% drawings, the slab is called-out as a composite slab. Upon further design by the engineer, is now corrected to be treated as a 6" concrete reinforced slab. The 2" 18 gage decking is considered sacrificial in the design. Analysis for this piece is done treating the piece as a composite deck where it is found that the system passes easily. Further analysis of 6" slab with no decking would likely yield a result showing that punching shear would control the design due to the high point loads dealt with in the design. For now no reinforcing is designed to analyze the deck from this approach. To the right is a cross section of the metal deck, slab, beam, and shear stud.

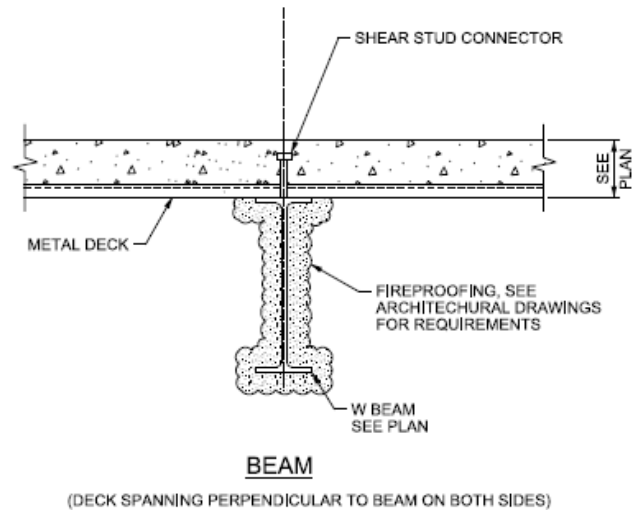

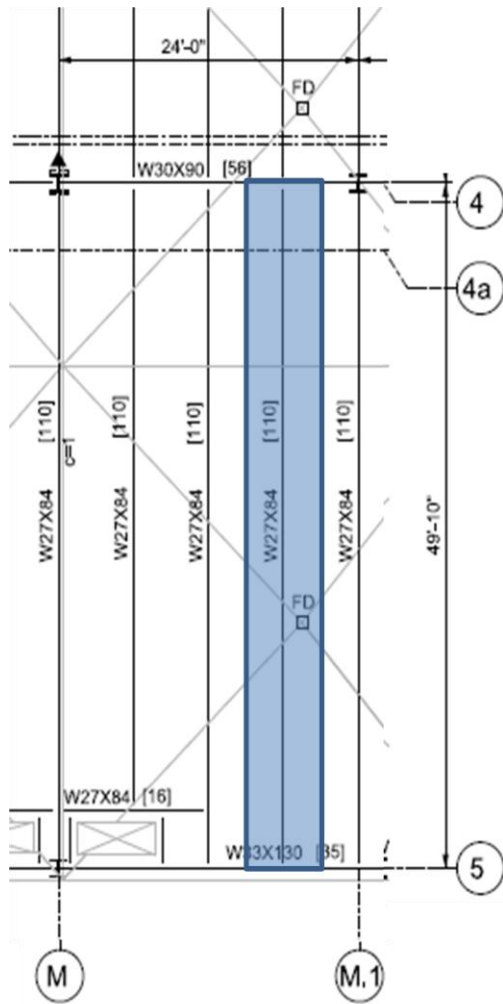

Beam Check:

The beam analyzed in this report is a W24x84 with a length of 49'10" and 110 shear studs located on the third floor of the New York City Bus Depot. This beam passes deflection tests and assumes the proper number of shear studs with use of the 6" concrete slab for analysis as opposed to the 8" composite deck system. Calculations for this member can be found in Appendix A. Shown to the left is the tributary area of loading highlighted over the beam in the analysis.

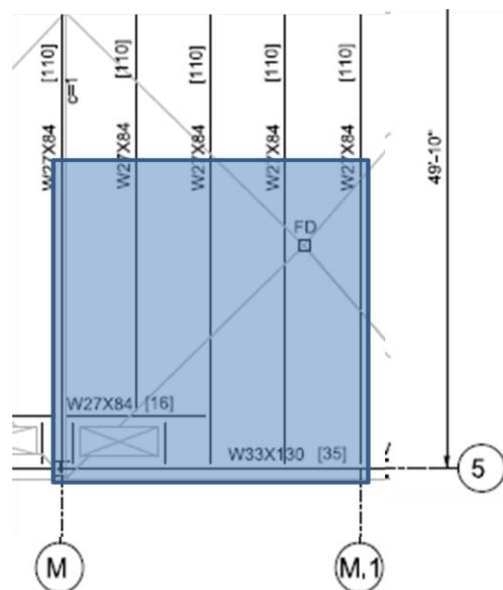

Girder Check:

The girder in this analysis is a W33x130 girder with a length of 24'. The analysis shows this girder to fail under the assumed conditions. This is again likely due to the misassumption of weight carried by the girder. Weights calculated from the distributed loads shown in Appendix F output a much higher weight than shown in new calculations from the structural engineer that are unable to be shown in this report.

The girder and the tributary loads used for the calculations in Appendix A are shown on the left.

Lateral Loads:

Wind Loads:

Design Criteria	
Importance Factor (I):	1.0
Occupancy Category:	II
Exposure:	C
Basic Wind Speed (V):	100 mph
Directionality Factor (kd):	1
Topographic Factor (kzt):	1.0
Gust Factor (G):	0.85 (rigid)

Wind loads were calculated to be lower than those provided in the drawings. Not all values were given. Those assumed included topographic factor and GCpi (assumed +/- 0.18 for an enclosed system). To the left is a table of the design criteria used in the analysis. Charts proceeding in this section show the achieved values through calculations shown in Appendix B. The values received show that wind is not the controlling factor in the lateral system, but instead seismic forces are.

Wind Pressures N-S Direction										
Type	Floor	Elevation (ft)	k _z (interpolated)	Velocity Pressure (psf)	C _p	Wind Pressure (psf):	Internal Pressure		Net Pressure	
							+GC _{pi}	-GC _{pi}	+GC _{pi}	-GC _{pi}
Windward Walls	1st	0	0.85	21.76	0.8	14.80	5.76	-5.76	20.56	9.04
	2nd	26	0.91	23.30	0.8	15.84	5.76	-5.76	21.60	10.08
	3rd	51	1.10	28.16	0.8	19.15	5.76	-5.76	24.91	13.39
	3rd (Mezz)	65	1.15	29.44	0.8	20.02	5.76	-5.76	25.78	14.26
	Roof	79	1.21	30.98	0.8	21.06	5.76	-5.76	26.82	15.30
	Parapet	84	1.22	31.23	0.8	21.24	5.76	-5.76	27.00	15.48
	Bulkhead	93	1.25	32.00	0.8	21.76	5.76	-5.76	27.52	16.00
Leeward Walls	All	All	1.25	32.00	-0.5	-13.60	5.76	-5.76	-7.84	-19.36
Side Walls	All	All	1.25	32.00	-0.7	-19.04	5.76	-5.76	-13.28	-24.80
Roof	N/A	0 to 46.5	1.25	32.00	-0.9	-24.48	5.76	-5.76	-18.72	-30.24
	N/A	46.5 to 93	1.25	32.00	-0.9	-24.48	5.76	-5.76	-18.72	-30.24
	N/A	93 to 186	1.25	32.00	-0.5	-13.60	5.76	-5.76	-7.84	-19.36
	N/A	>186	1.25	32.00	-0.3	-8.16	5.76	-5.76	-2.40	-13.92

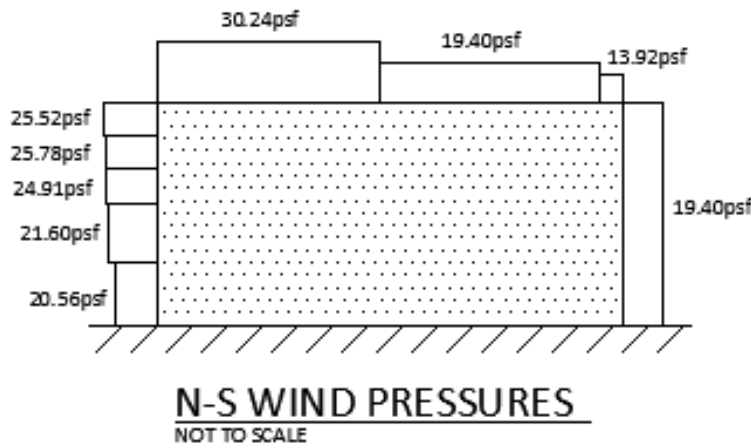

Wind Forces N-S								
Floor	Elevation (ft)	Trib. Below		Trib. Above		Story Force (k)	Story Shear (K)	Overturning Moment (k.ft)
		Height (ft)	Area (ft2)	Height (ft)	Area (ft2)			
1st	0	0.0	0.0	13.0	8372.0	172.10	1437.63	0.00
2nd	26	13.0	8372.0	12.5	8050.0	354.74	1265.53	4611.57
3rd	51	12.5	8050.0	7.0	4508.0	312.80	910.80	3910.06
3rd (Mezz)	65	7.0	4508.0	7.0	4508.0	232.43	597.99	1626.98
Roof	79	7.0	4508.0	2.5	1610.0	164.11	365.57	1148.75
Parapet	84	2.5	1610.0	4.5	2898.0	121.71	201.46	304.26
Bulkhead	93	4.5	2898.0	0.0	0.0	79.75	79.75	358.89
Total Base Shear:								1437.63
Total Overturning Moment:								133699.95

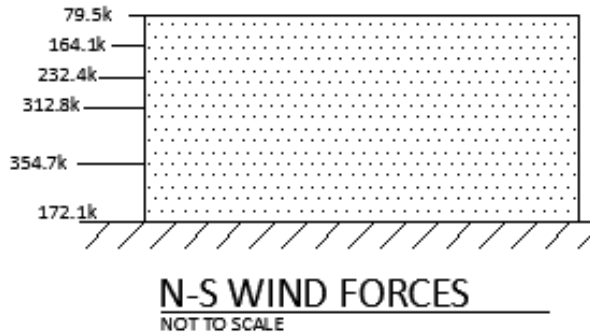

Wind Pressures E-W Direction										
Type	Floor	Elevation (ft)	k _z (interpolated)	Velocity Pressure (psf)	C _p	Wind Pressure (psf)	Internal Pressure		Net Pressure	
							+GC _{pi}	-GC _{pi}	+GC _{pi}	-GC _{pi}
Windward Walls	1st	0	0.85	21.76	0.8	14.80	5.76	-5.76	20.56	9.04
	2nd	26	0.91	23.30	0.8	15.84	5.76	-5.76	21.60	10.08
	3rd	51	1.10	28.16	0.8	19.15	5.76	-5.76	24.91	13.39
	3rd (Mezz)	65	1.15	29.44	0.8	20.02	5.76	-5.76	25.78	14.26
	Roof	79	1.21	30.98	0.8	21.06	5.76	-5.76	26.82	15.30
	Parapet	84	1.22	31.23	0.8	21.24	5.76	-5.76	27.00	15.48
	Bulkhead	93	1.25	32.00	0.8	21.76	5.76	-5.76	27.52	16.00
Leeward Walls	All	All	1.25	32.00	-0.3	-7.34	5.76	-5.76	-1.58	-13.10
Side Walls	All	All	1.25	32.00	-0.7	-19.04	5.76	-5.76	-13.28	-24.80
Roof	N/A	0 to 46.5	1.25	32.00	-0.9	-24.48	5.76	-5.76	-18.72	-30.24
	N/A	46.5 to 93	1.25	32.00	-0.9	-24.48	5.76	-5.76	-18.72	-30.24
	N/A	93 to 186	1.25	32.00	-0.5	-13.60	5.76	-5.76	-7.84	-19.36
	N/A	>186	1.25	32.00	-0.3	-8.16	5.76	-5.76	-2.40	-13.92

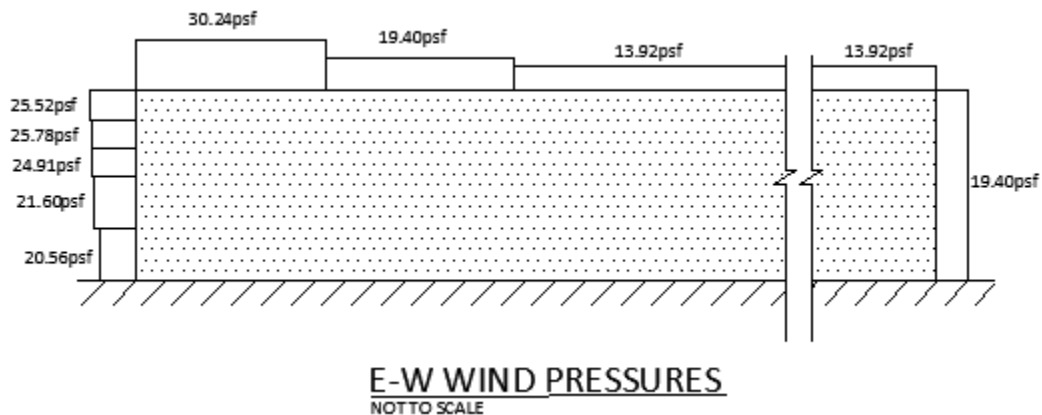

Wind Forces E-W									
Floor	Elevation (ft)	Trib. Below		Trib. Above		Story Force (k)	Story Shear (K)	Overturning Moment (k.ft)	
		Height (ft)	Area (ft2)	Height (ft)	Area (ft2)				
1st	0	0.0	0.0	13.0	2541.5	52.25	436.42	0.00	
2nd	26	13.0	2541.5	12.5	2443.8	107.69	384.18	1399.94	
3rd	51	12.5	2443.8	7.0	1368.5	94.96	276.49	1186.98	
3rd (Mezz)	65	7.0	1368.5	7.0	1368.5	70.56	181.53	493.90	
Roof	79	7.0	1368.5	2.5	488.8	49.82	110.98	348.73	
Parapet	84	2.5	488.8	4.5	879.8	36.95	61.16	92.37	
Bulkhead	93	4.5	879.8	0.0	0.0	24.21	24.21	108.95	
Total Base Shear:								436.42	
Total Overturning Moment:									40587.48

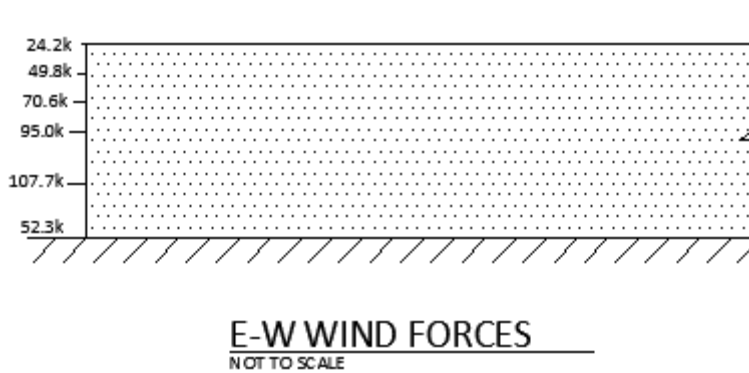

Seismic Loads:

Base Shears			
Direction	C _s	V (k)	Error
(NS)	0.05	3847.9227	3.5%
(EW)	0.053	4078.79806	-7.4%

The following series of charts presents a summary of the results of the seismic analysis of the New York City Bus Depot. Minimal error is noted in comparison to the base shear showing in the drawings, despite

the difference in weight between the engineer’s report and this analysis.

The analysis output for base shear shown in the 65% drawings give only one shear for the north-south direction and one shear for the east-west direction. A more detailed analysis from the structural engineer that cannot be shown in this report shows that the building should instead be analyzed in three different parts due to the separation seen along the expansion joints. This analysis was received too late to be a part of this report.

For further detail on the calculations, see Appendix C for a calculation check sheet.

N-S Seismic Analysis									
Floor	Distributed Floor Dead Load (psf)	Area (ft ²)	Elevation (ft):	Weight (k):	$w_x h_x^k$	C_{vx}	NS Story Force	NS Story Shear (k)	NS Overturning Moment (k-ft)
Floor 1	200	125902.0	0	25682.90	0.00	0.00	0.00	3847.92	0.00
Floor 2	100	125902.0	26	13512.50	351325.00	0.16	630.24	3847.92	16386.22
Floor 3	100	125902.0	51	13212.40	673832.40	0.31	1208.78	3217.68	61647.91
Floor 3 (Mezz)	100	13489.5	65	1378.95	89631.75	0.04	160.79	2639.14	10451.33
Roof	100	112412.5	79	11431.15	903060.85	0.42	1619.99	3687.13	127979.50
High Roof	100	13489.5	93	1367.35	127163.55	0.06	228.12	2227.93	21214.94
Total Overturning Moment:									237679.90

E-W Seismic Analysis									
Floor	Distributed Floor Dead Load (psf)	Area (ft ²)	Elevation (ft):	Weight (k):	$w_x h_x^k$	C_{vx}	EW Story Force	EW Story Shear (k)	EW Overturning
Floor 1	200	125902.0	0	25682.90	0.00	0.00	0.00	4078.80	0.00
Floor 2	100	125902.0	26	13512.50	351325.00	0.16	668.05	4078.80	17369.39
Floor 3	100	125902.0	51	13212.40	673832.40	0.31	1281.31	3410.74	65346.79
Floor 3 (Mezz)	100	13489.5	65	1378.95	89631.75	0.04	170.44	2797.49	11078.41
Roof	100	112412.5	79	11431.15	903060.85	0.42	1717.19	3908.36	135658.27
High Roof	100	13489.5	93	1367.35	127163.55	0.06	241.80	2361.60	22487.84
Total Overturning Moment:									251940.69

Conclusion:

Through the analysis of this building a better understanding of the structural systems used is achieved. The analysis of this building yields a mixed result of failing and passing members and systems. Much of this is likely due to assumptions that are made within the calculations. Complications arise due to assumptions in the drawings that are not clearly stated. The assumption of an improper weight is likely the cause of most member failure.

Gravity checks show that members are within on e size of necessary support for the structure which leads to a believe that assumptions lead to miscalculations. More detailed analysis may also lead to better results.

An analysis of the lateral system yields results that the frames within the building are most likely adequate and over designed for the loads they will need to carry, particularly in the case of wind because the seismic analysis proves governance over the calculated members.

In conclusion, further analysis is necessary and more information needs to be provided beyond the 65% submittal drawings, which will help to gain a better understanding of this building and its systems.

Appendix A: Gravity Load Calculations

BEAM CHECK

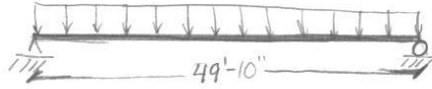

tributary width: 6'-0"

Given: W27x84
[110] shear studs

$I_x = 2850 \text{ in}^4$ CDL: 85 psf
 $A_s = 28.4 \text{ in}^2$ SDL: 35 psf
 $f_y = 50 \text{ ksi}$ LL: 175 psf
 $f'_c = 5 \text{ ksi}$ Self wt: 84 plf

ASD:

$w = D + L$
 $(85 + 35) (6') + 84 \text{ plf} + 175 (6') \text{ plf}$
 $1860 \text{ plf} = 1.86 \text{ KIP}$

Moment: $\frac{wl^2}{8} = \frac{1.86(49.83)^2}{8} = 577 \text{ k}\cdot\text{ft} < 609 \text{ k}\cdot\text{ft} \checkmark$

Shear: $\frac{wl}{2} = \frac{1.86(49.83)}{2} = 46 \text{ k} < 246 \text{ k} \checkmark$

Deff: $\frac{\text{span}}{4} = 14'$
 min spacing: 6' ← CONTROLS

$A_s f_y =$

PNA LOCATION:

$V_c = 0.85 f'_c (b_{\text{eff}}) t = 1886 \text{ k}$
 $V_s = A_s f_y = 28.4 (50) = 1420 \text{ k}$

* $t = 6''$ because design considers deck to be "sacrificial." Therefore, design is treated as though no deck is involved.

$\Sigma Q_n = 1420 \text{ k} \leq n Q_n / 2$
 $n = 108.8 \sim \underline{110} \checkmark$

\downarrow
 $Q_n = 26.1 \text{ kip}$

W27x84 Works

BEAM CHECK (cont)

Deflection Check:

$$\Delta_{LL} = \frac{L}{360} = \frac{49.83(12)}{360} = 1.661 \text{ in}$$

$$I_{req} = \frac{1430k}{1850k} = \frac{a}{b} \quad a = 4.64''$$

← sacrificial deck

$$Y2 = 0 - 4.64 = 1.30 - 2'' = 3.34''$$

$$I_{LB} \sim 0.332 \text{ in}^4 \leftarrow \text{interpolated}$$

$$\Delta_{LL} = \frac{5wL^4}{384EI} = \frac{5(1.65 \text{ plf}/12)(49.83 \times 12)^4}{384(29000)(0.332)} = 0.79 \text{ in} \checkmark \text{ OK}$$

$\triangleleft \Delta_{LL \text{ MAX}}$

$$I_{REQ'D} = \frac{L}{240} = \frac{49.83(12)}{240} = 2.49'' = \Delta_{max}$$

$$I_{REQ} = \frac{5wL^4}{384E\Delta_{max}} = \frac{5(85 \times 0 + 84 \text{ plf})(12)(49.83 \times 12)^4}{384(29000)(2.49)} = 459.6 \text{ in}^4 \checkmark$$

$\triangleleft I_{LB}$

(checked for Δ under wet concrete)

W27x84 GOOD

COLUMN CHECK

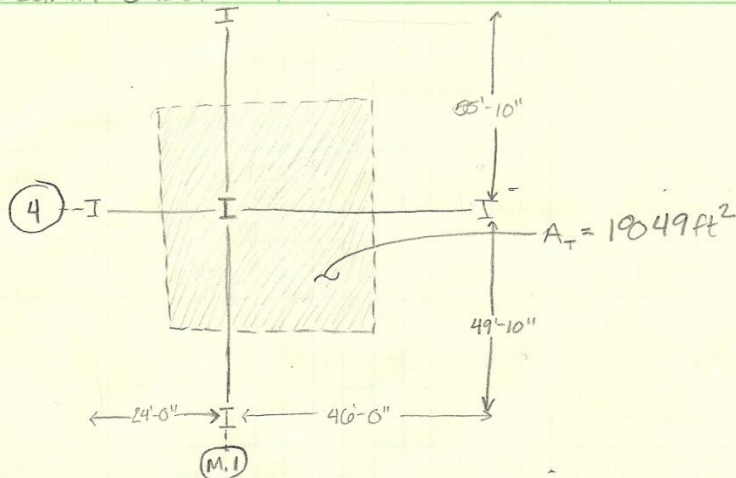

Live Load Reduction:

$$0.25 + \frac{15}{\sqrt{4 \times 1849}} = 0.42$$

Roof: CDL: 67 psf
SDL: 95 psf
LL: 30 psf

2nd: 3rd: CDL: 85
SDL: 35
LL: 125

3rd FL COL:

$$P_L = 0.42(30 \times 1849) = 23.3 \text{ k}$$

$$P_D = 1849(67 + 95) = 299.5 \text{ k}$$

$$P_u = 299.5 + 23.3 = 322.8 \text{ k} \leftarrow \underline{\text{ASD}}$$

2nd FL COL:

$$P_L = 23.3 \text{ k} + 0.42(1849 \times 125/1000) = 120.4 \text{ k}$$

$$P_D = 299.5 \text{ k} + [1849(85 + 35)] = 521.4$$

$$P_u = 641.8 \text{ k}$$

1st FL COL:

$$P_L = 120.4 + 0.42(1849 \times 125) = 217.4 \text{ k}$$

$$P_D = 521.4 + 1849(35 + 85) = 743.26$$

$$P_u = 1264.66 \text{ k}$$

Unbalanced Moment @ Top of 3rd FL COL:

$$M = \frac{w_u l^2}{12} = \frac{(30 \times 52.83)(40')^2}{12} = 279.5 \text{ k}\cdot\text{ft}$$

UNBAL MOM @ TOP OF 1st & 2nd FL COLS:

$$M = \frac{w_u l^2}{12} = \frac{(125 \times 52.83)(40')^2}{12} = 1164.5 \text{ k}\cdot\text{ft} \left(\begin{array}{l} 1/2 \text{ to col } \uparrow \\ 1/2 \text{ to col } \downarrow \end{array} \right)$$

COLUMN CHECK (cont)

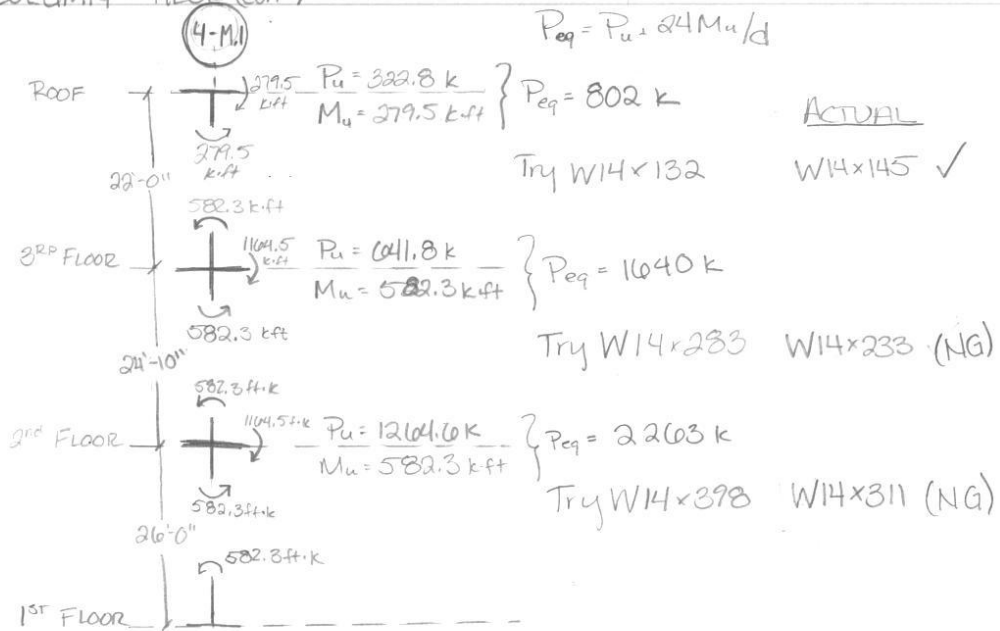

GIRDER CHECK

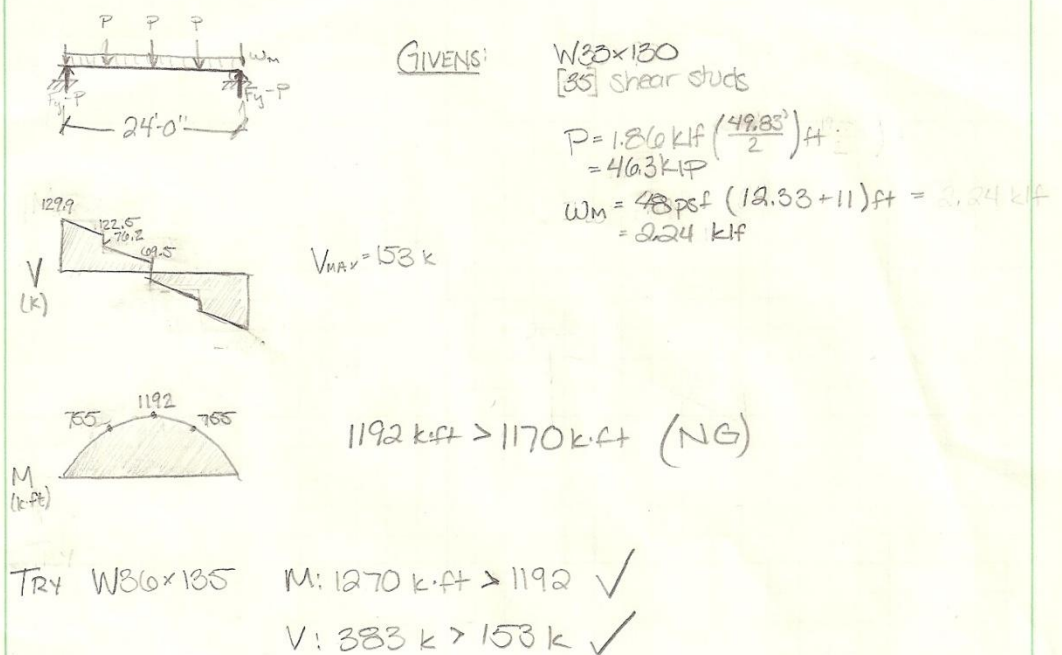

GIRDER W33x130 FAILS

Appendix B: Wind Load Calculations

Wind Load Calcs	AE Senior Thesis	TRIEBL	1
<p>Location: New York City Terrain: Urban Framing: Steel, Enclosed</p>			
<p><u>DESIGN CRITERIA:</u> MWFRS Importance Factor: 1.0 Occupancy Category: II Exposure: C Basic Wind Speed: 100 mph</p>			
<p><u>Velocity Pressure:</u> $q_z = 0.00256 k_z k_{zt} k_d V^2 I$ $k_z = 1.24$ $k_{zt} = 1.0$ $k_d = 0.85$ $V = 100 \text{ mph}$ $I = 1.0$</p>			
<p>$q_z = 0.00256(1.24)(1.0)(0.85)(100^2)(1.0)$ $= 26.98 \text{ psf}$</p>			
<p>$q_n = 26.98 \text{ psf @ } h = 93'$</p>			
<p><u>Gust factor:</u> (6.5.8)</p>			
<p>Find Natural frequency first:</p>			
<p>$T_n = C_t h_n^x$</p>			
<p>*RIGID STRUCTURE - SEE SEISMIC CALCS</p>			
<p>$T_n = 1.0$</p>			
<p>$G = 0.85$ (6.5.8.1)</p>			
<p><u>Internal Pressure Coefficient:</u></p>			
<p>$GC_{pi} = \pm 0.18$</p>			
<p><u>External Pressure Coefficient:</u></p>			
<p>Wall C_p: • Windward: 0.8 Leeward: L/B (604' wall): 0.304 $C_p = -0.5$ • Sidewall: -0.7 L/B (195'-6" wall): 3.29 $C_p = -0.27$ (interpol.) *B: Normal to wind *L: Parallel to wind</p>			

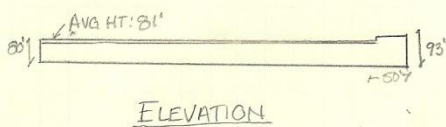
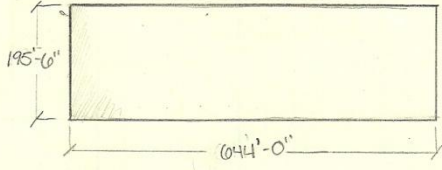

WIND LOAD CALCS	AE SENIOR THESIS	TRIEBL	2										
<p>*Roof C_p: h/L: 0.48 to 0.14 : both ≤ 0.5</p> <table border="0" data-bbox="341 388 795 541"> <tr> <td>Horiz. Dist. from windward edge:</td> <td>C_p</td> </tr> <tr> <td>0 to $h/2$: (0 to 46'-6")</td> <td>-0.9</td> </tr> <tr> <td>$h/2$ to h: (46'-6" to 93')</td> <td>-0.9</td> </tr> <tr> <td>h to $2h$: (93' to 186')</td> <td>-0.5</td> </tr> <tr> <td>$>2h$: ($>186'$)</td> <td>-0.3</td> </tr> </table> <p>* Second Value for Load Comes with Snow & Live Load</p>				Horiz. Dist. from windward edge:	C_p	0 to $h/2$: (0 to 46'-6")	-0.9	$h/2$ to h : (46'-6" to 93')	-0.9	h to $2h$: (93' to 186')	-0.5	$>2h$: ($>186'$)	-0.3
Horiz. Dist. from windward edge:	C_p												
0 to $h/2$: (0 to 46'-6")	-0.9												
$h/2$ to h : (46'-6" to 93')	-0.9												
h to $2h$: (93' to 186')	-0.5												
$>2h$: ($>186'$)	-0.3												
<p><u>MWERS PRESSURES: RIGID STRUCTURE</u></p>													
<p>$P = q G C_p - q_i (G C_{pi})$</p>													
<p><u>Parapet:</u></p>													
<p>$P = q_p (G C_p - G C_{pi})$</p>													

Appendix C: Seismic Load Calculations

SEISMIC DESIGN	AE SENIOR THESIS	TRIEBL	1												
<u>DESIGN CRITERIA:</u>															
Importance Factor: 1.0 Seismic Use Group: 1 Seismic Design Category: C Mapped Spectral Response: $S_s = 0.28g$ $S_{ds} = 0.448$ $S_1 = 0.06g$ $S_{d1} = 0.14$ } Confirmed w/ 2010 New York State Building Code Fundamental Period: $0.48s$															
<table border="1"> <thead> <tr> <th></th> <th>N-S</th> <th>E-W</th> </tr> </thead> <tbody> <tr> <td>LFRS</td> <td>Monument Frames</td> <td>Concentrically Braced Frames</td> </tr> <tr> <td>C_s</td> <td>0.048</td> <td>0.060</td> </tr> <tr> <td>R</td> <td>3.5</td> <td>3.25</td> </tr> </tbody> </table>					N-S	E-W	LFRS	Monument Frames	Concentrically Braced Frames	C_s	0.048	0.060	R	3.5	3.25
	N-S	E-W													
LFRS	Monument Frames	Concentrically Braced Frames													
C_s	0.048	0.060													
R	3.5	3.25													
• Checking Spectral Response Acceleration Parameters: $S_s = 0.15$ $F_a = 2.5$ $S_{ms} = 0.375$ $S_{ds} = 0.25$ $S_s = 0.28g$ $F_a = 2.4$ (interpolated) $S_{ms} = F_a S_s = 0.672$ $S_{ds} = \frac{2}{3} S_{ms} = 0.448$ ✓ $S_1 = 0.06g$ $F_v = 3.5$ $S_{m1} = F_v S_1 = 0.21$ $S_{d1} = \frac{2}{3} S_{m1} = 0.14$ ✓															
• Check Fundamental Period: $T_a = C_t h_N^x = 0.2 (72.7)^{0.75}$ ← height to roof w/out parapet $= 0.49 \text{ sec}$ ✓ ← defined on S-003 as $0.48s$ $T = C_u T_a = 1.02(0.49) = 0.806s$ $T_L = 6 \text{ sec}$ $C_s = \frac{S_{ds}}{R/I} = \frac{0.25}{3.5} = 0.071$ ← NS $T < T_L$ ✓ $C_e = \frac{S_{ds}}{R/I} = \frac{0.25}{3.25} = 0.077$ ← EW $C_s < S_{d1} / (R/I) T = 0.14 / (3.5/1.0)(0.806) = 0.050$ ← NS $C_s < S_{d1} / (R/I) T = 0.14 / (3.25/1.0)(0.806) = 0.053$ ← EW } CONTROLS $C_s \geq 0.01$ (NS : EW)															

Appendix D: Framing Plans

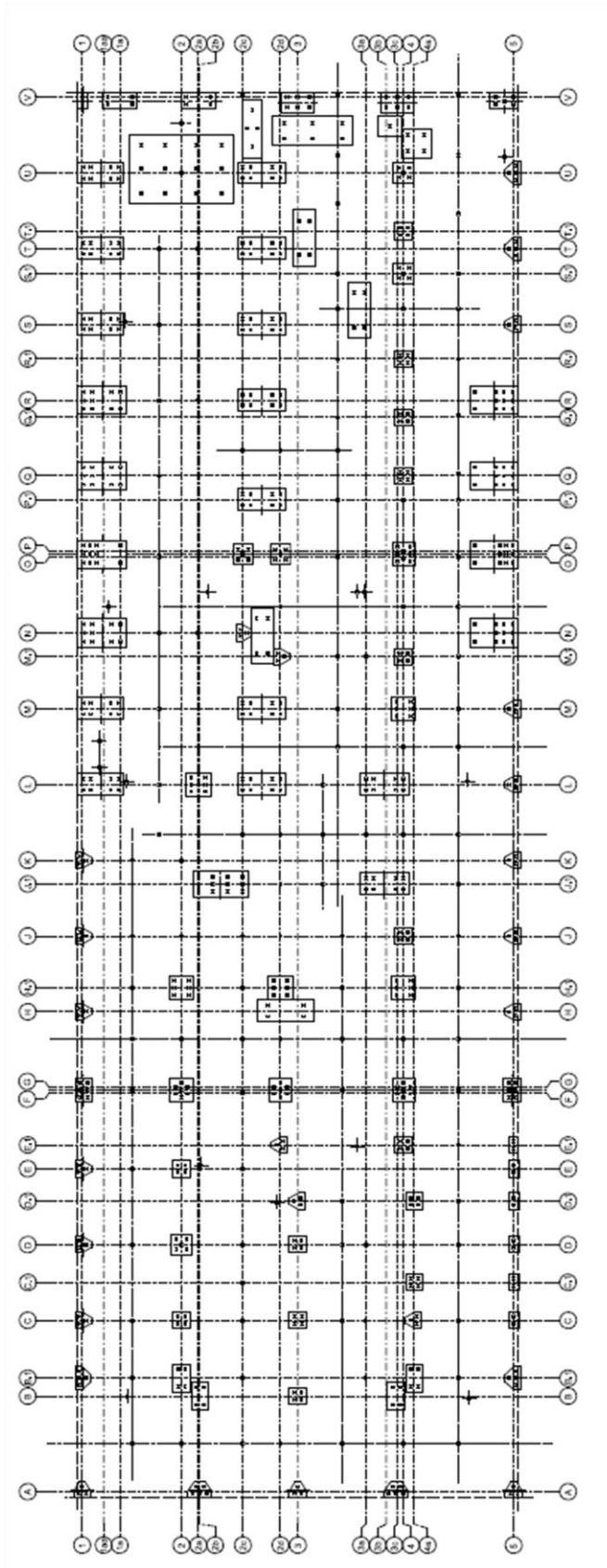

Foundation Plan

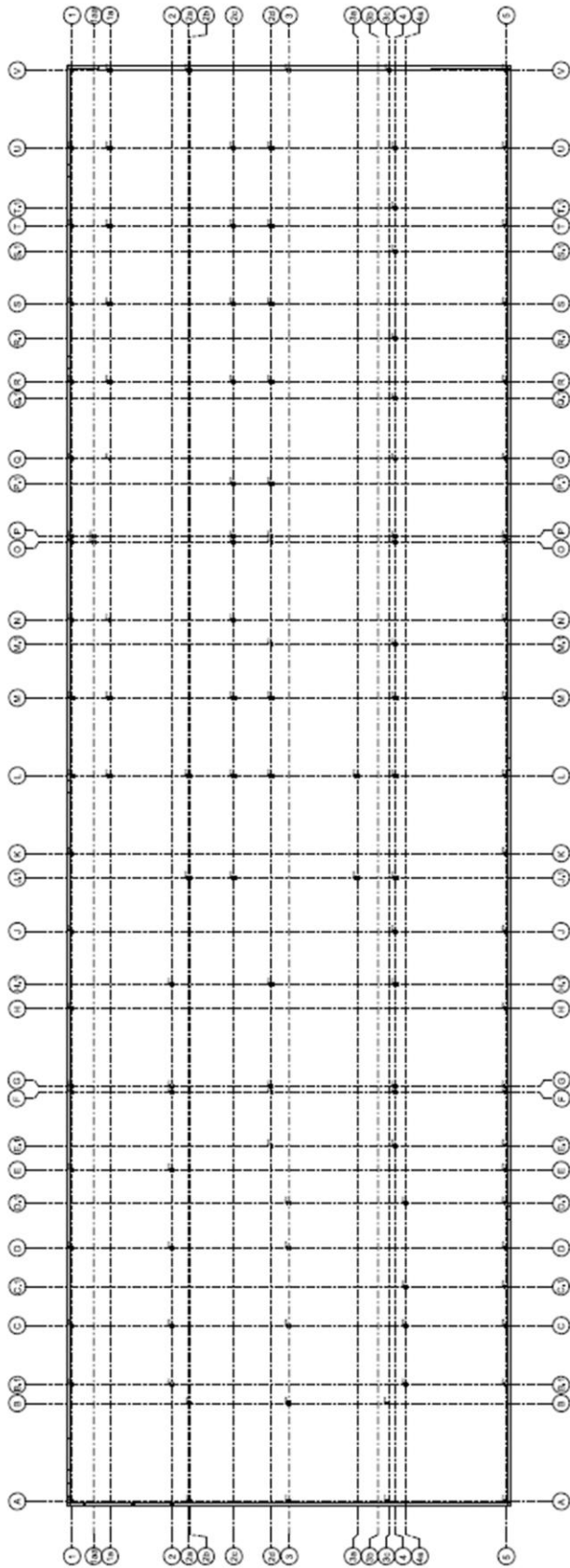

First Floor Plan



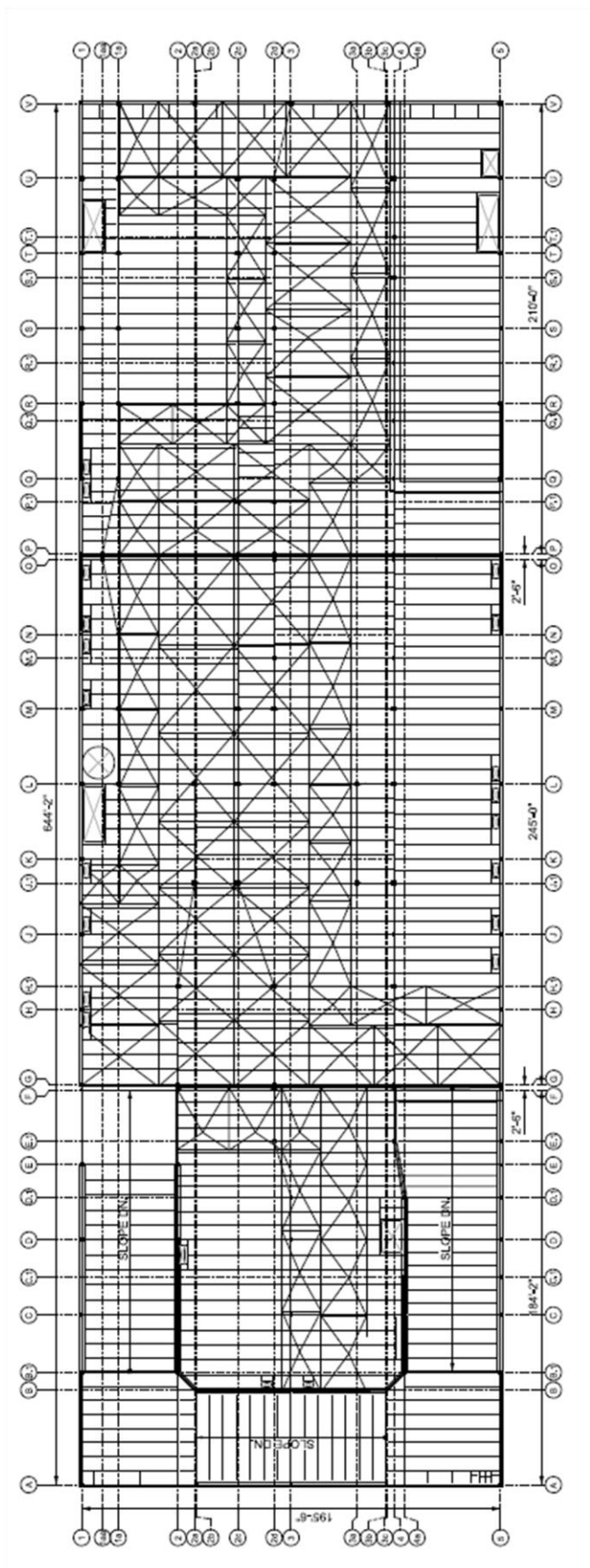

Second Floor Framing Plan

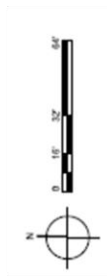

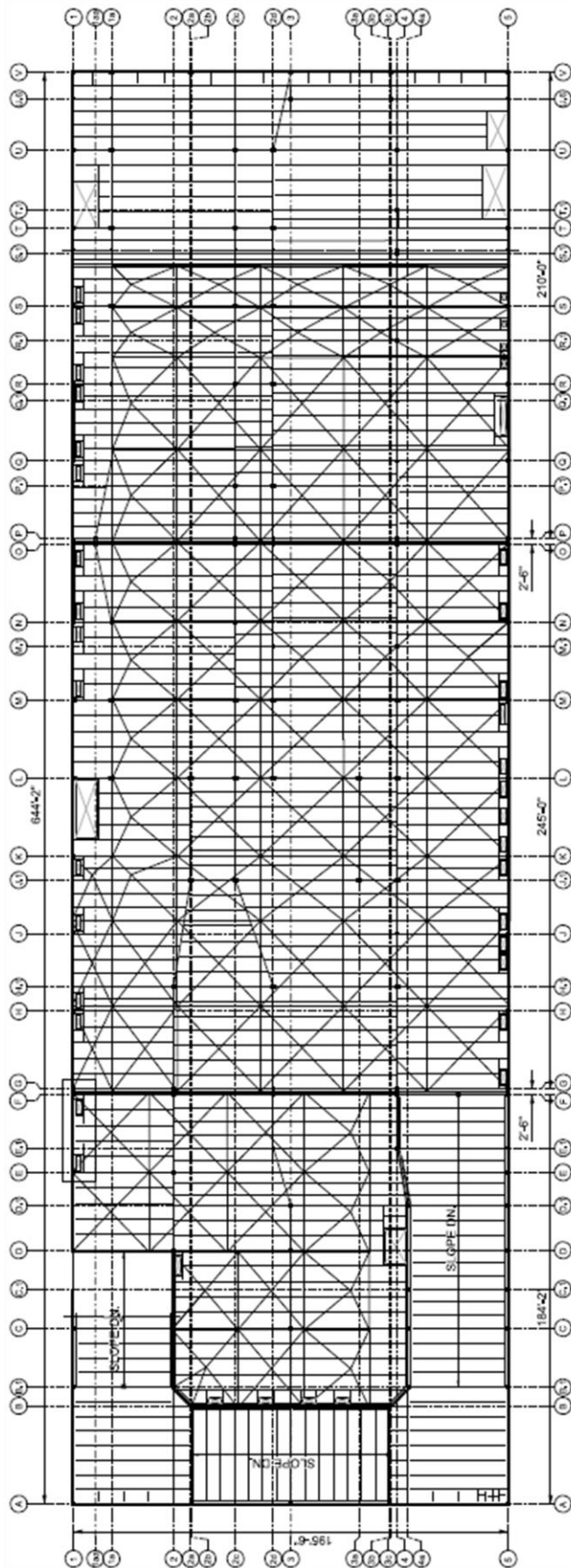

Third Floor Framing Plan

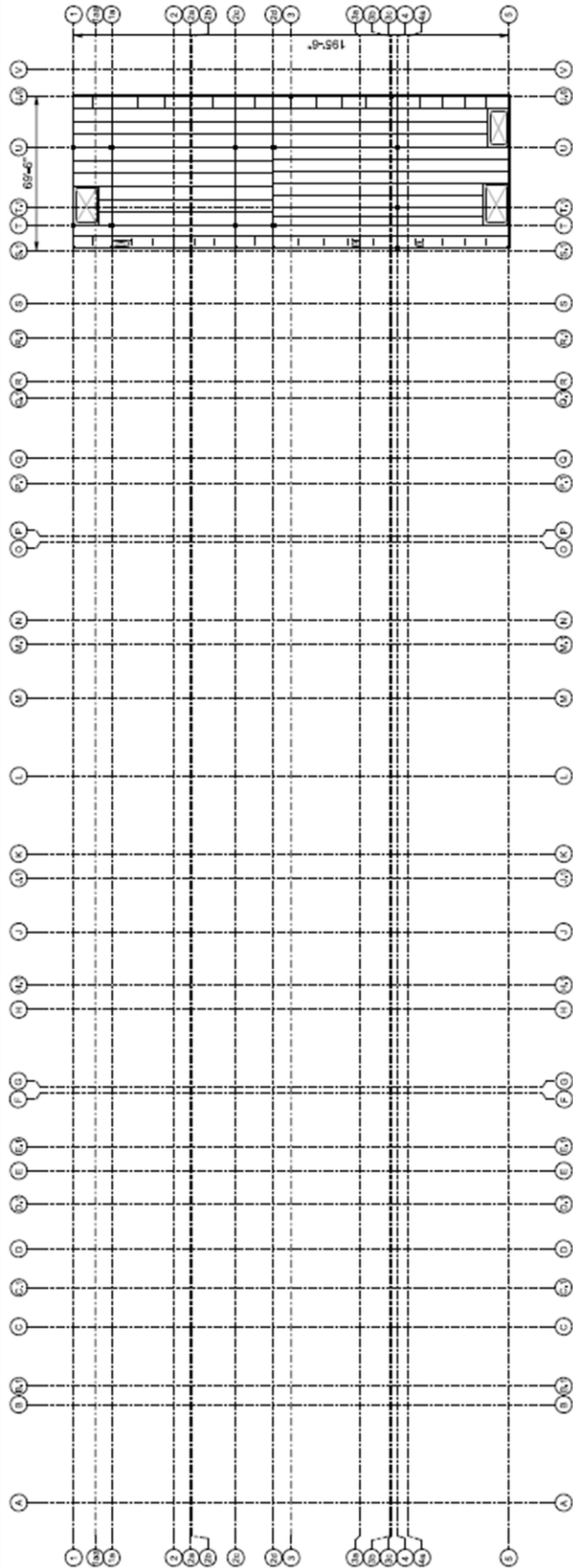

Third Floor Mezzanine Framing Plan

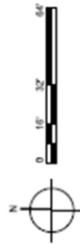

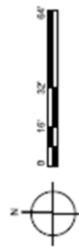
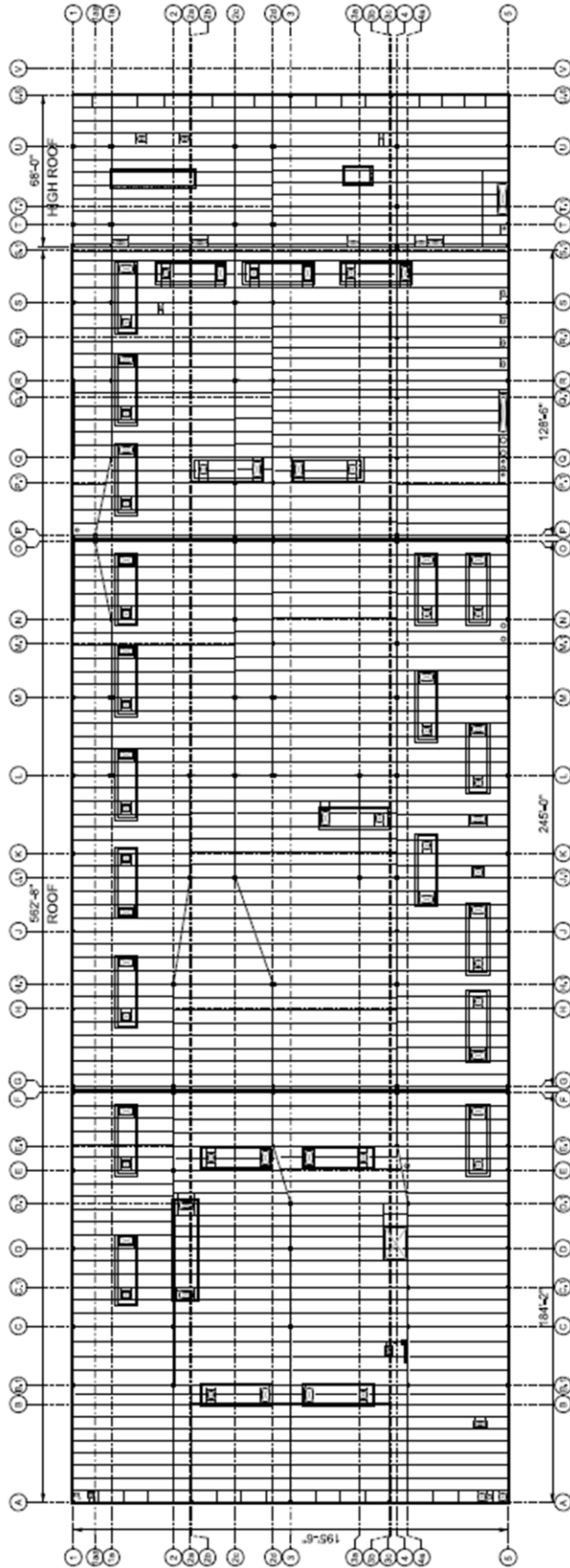

Composite Roof and High Roof Framing Plan

Appendix E: Distributed Loads

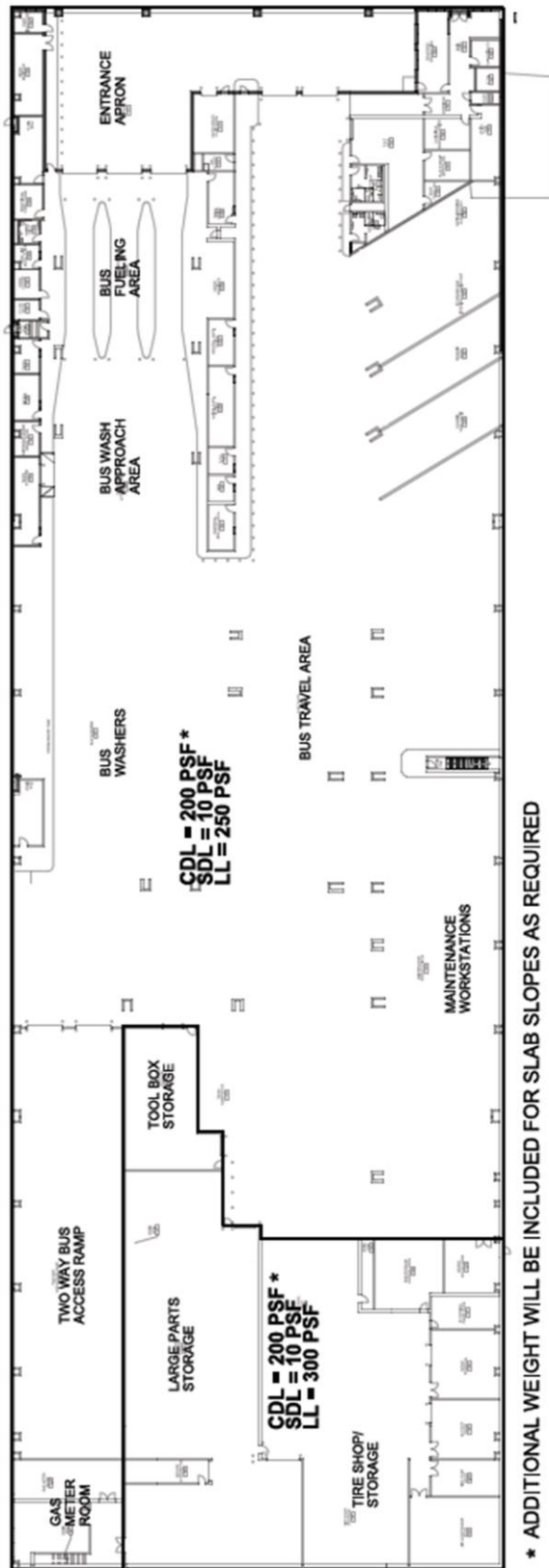

First Floor Load Map

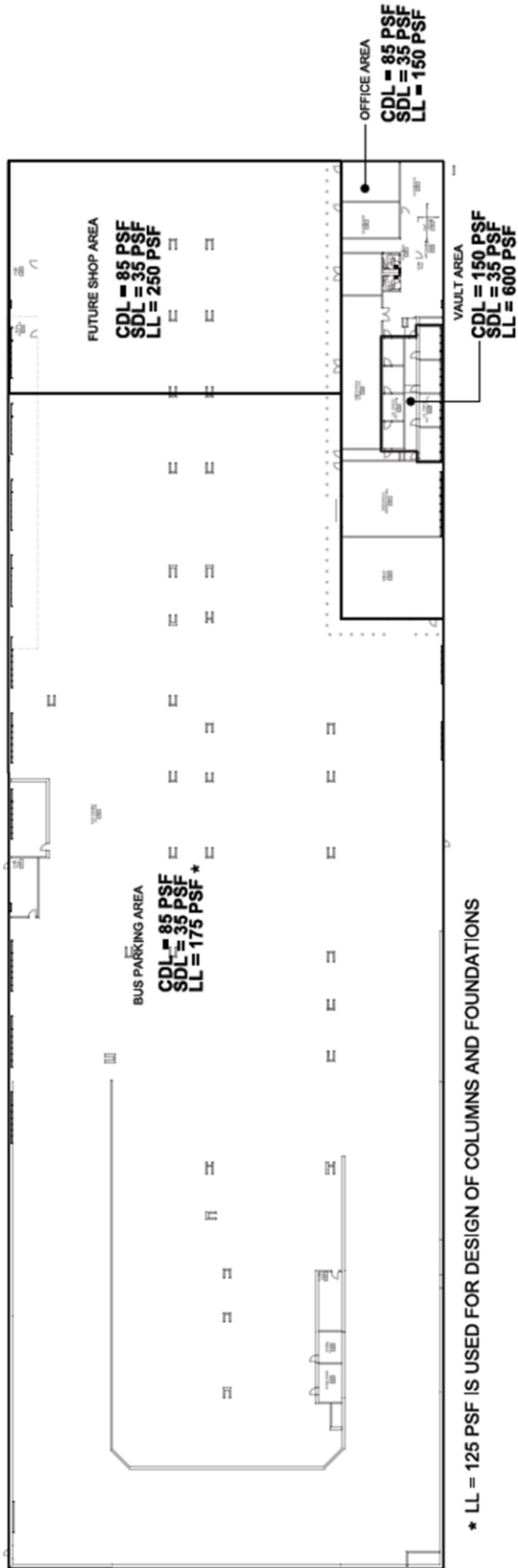

Second Floor Load Map



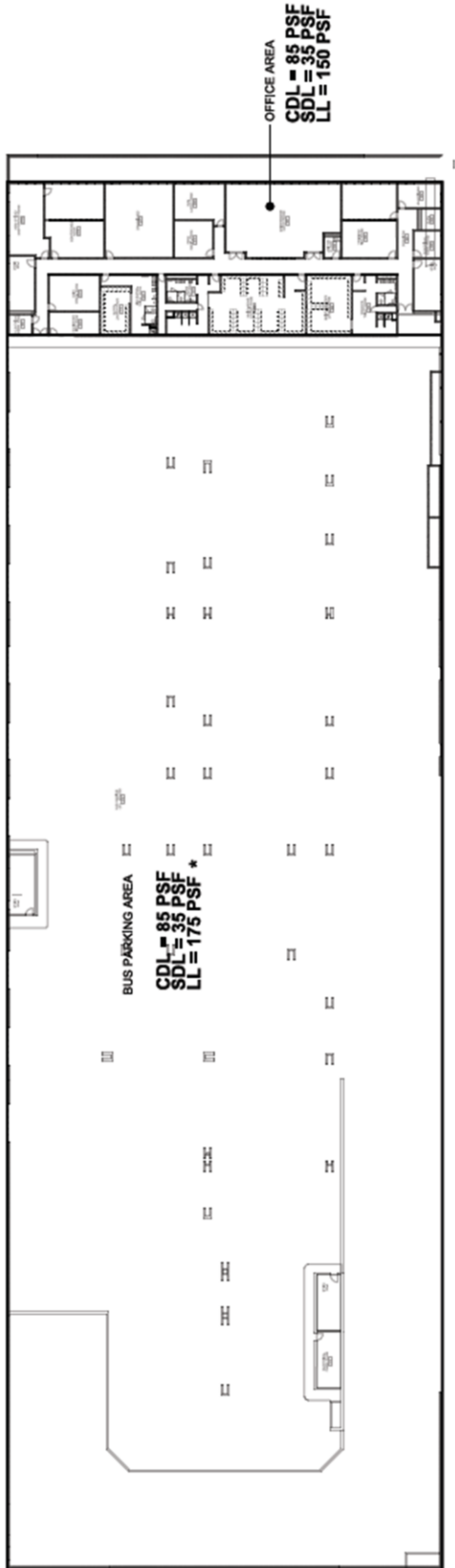

Third Floor Load Map

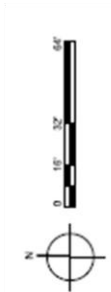
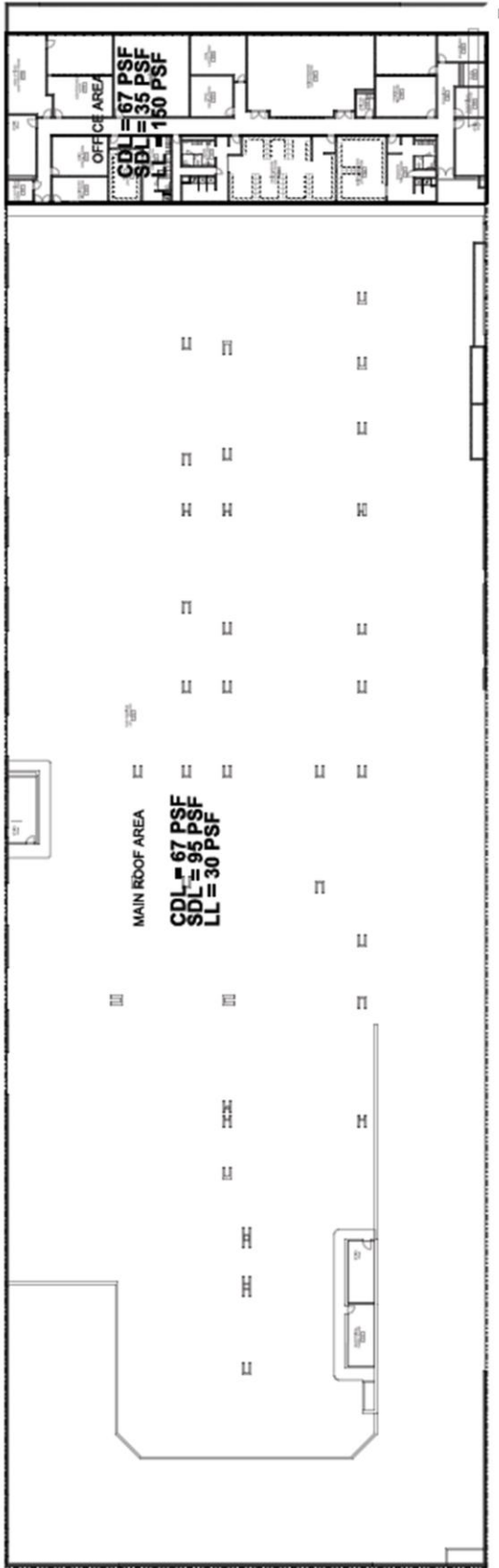

Roof and Third Floor Mezzanine Load Map

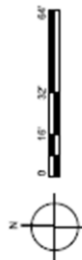

High Roof Load Map